

BLW series

High speed, Extra large vertical axis hook, Automatic thread trimmer, Automatic back tack, Automatic presser foot lift, Climbing device, Dual stitching device, Compound feed and walking foot, Lockstitch machines



BLW-8BLCE-DM

Variety



BLW-8BLCE-DM

Single needle, Direct drive motor, E type presser foot (*)



BLW-8BLCS-DM

Single needle, Direct drive motor, S type presser foot (*)



BLW-8BLCE

Single needle, E type presser foot (*)



BLW-8BLCS

Single needle, S type presser foot (*)



BLW-28BLCE-DM

Two needle, Direct drive motor, E type presser foot (*)



BLW-28BLCS-DM

Two needle, Direct drive motor, S type presser foot (*)



BLW-28BLCE

Two needle, E type presser foot (*)



BLW-28BLCS

Two needle, S type presser foot (*)

(*)Two types of Presser foot, E-type European style and S-type American style, are available.

Applications

- For sewing medium to heavy weight materials such as leather, vinyl, synthetics and laminated and coated materials.
- Suitable for sewing such as automobile upholstery, tarpaulins, covers, awnings, tents, umbrellas, handbags, luggage, travelware accessories, sports and camping equipment and wearing apparel outdoor clothing.



Features

- Built-in Direct Drive Motor Models

- * Built-in 850W direct drive motor models are also available that will make setting works easier. (**DM** models)

- Secure Feeding

- * Compound Feeding System to make the secure stitches on heavy duty materials, even on slippy or uneven materials.

- Extra Large Size Hook

- * 2.7 times large vertical axis hook is equipped for lesser bobbin replacement.

- One touch switchover for two different stitch lengths (DS device)

- * Variety sewing materials such as steps, curves, uneven thickness can be performed by one touch switchover setting two different stitch lengths. The efficient work and beautiful finishes will be obtained.

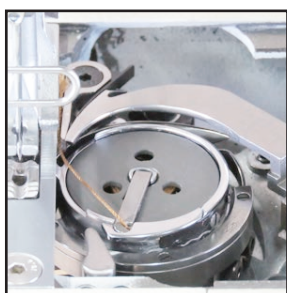

2.8 times large capacity hook

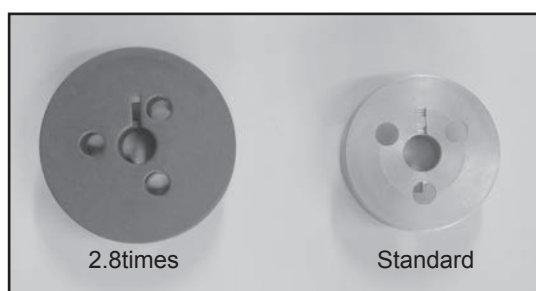

Comparison of the bobbin size



One touch switchover for two different stitch lengths (DS device)

- Built-in bobbin winder

- * Built-in bobbin winder makes it possible to wind the bobbin thread during sewing operation.

- Wide working space

- * Wide working space 13-25/32" x 5-1/8" (350mm x 130mm).

- Good Operability.

- * Presser foot lift amount 25/32" (20 mm) (by automatic foot lifter).
Needle bar stroke 1-37/64" (40 mm).
Alternating presser foot lift amount 3/64" - 23/64" (1 mm - 9 mm).
- * Adopted a 850W powerful motor for both of a motor built-in model and an outside-motor model in order to strengthen a penetration.



Built-in bobbin winder with fine adjustment function of thread winding amount

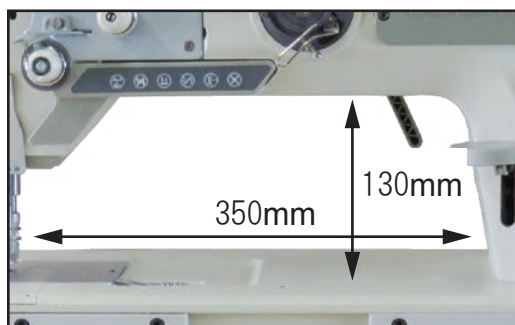

Wide working space

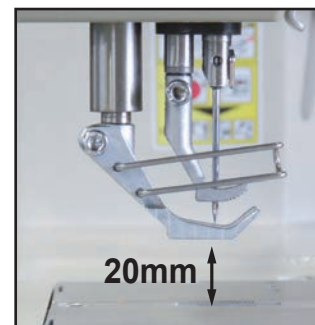

The clearance under the presser foot (20mm)

BLW series

- Simple setting for alternating presser foot movement
 - * Alternating presser foot movement between inner foot and outer foot can be changed simply by the easy-to-handle dial located at the top of the sewing machine.
- LCD Touch Panel for Easy Setting for Sewing
 - * LCD Touch panel is equipped at front that will make setting works for sewing condition easier.

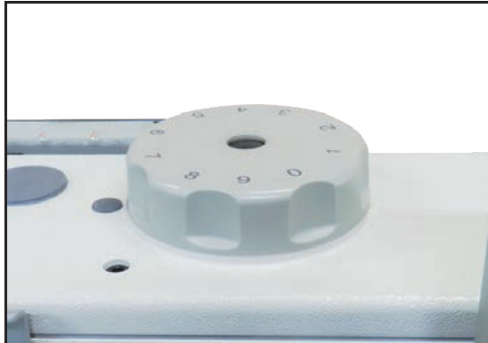

Simple setting for alternating presser foot movement



LCD operation touch-panel

- 6 Functional Buttons and Quick Back-Tacking Switch
 - * 6 functional buttons and quick back-tacking switch are equipped at front that will make operation easier even during sewing.
 - Various additional functions will increase working efficiency.
- Smooth stitching on step section (CD device)
 - * Can change the presser foot step maximum 9 mm higher by button right before the uneven point that makes smoother stitching.

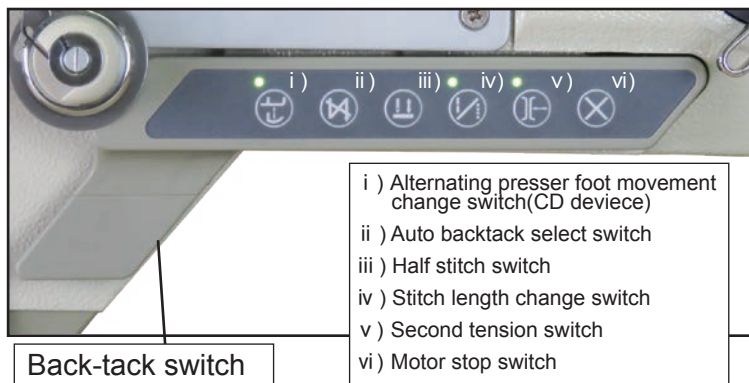

Back-tack switch and 6 button operation panel

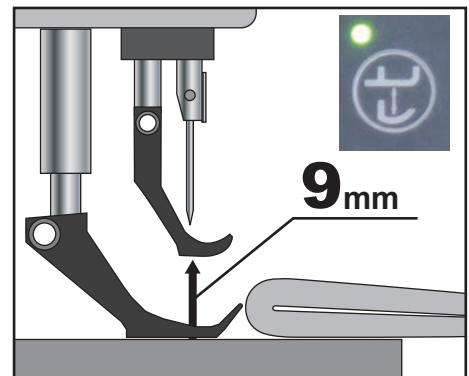

Smooth stitching on step section (CD device)

- Guide (optional parts)

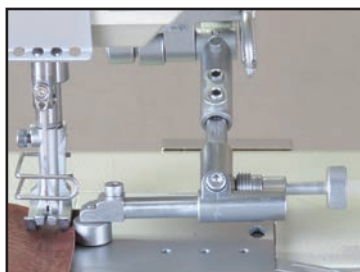

On duty

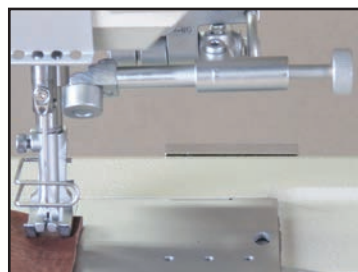

Off duty

- Lubrication
 - * Automatic lubrication system.
- Automatic Thread Trimmer, Automatic Back-tacking and Automatic Presser Foot Lifting
 - * Those are already equipped as standard functions.

Specifications (BLW-□)

Variety	8BLCE-DM 8BLCS-DM	28BLCE-DM 28BLCS-DM	8BLCE 8BLCS	28BLCE 28BLCS
Number of needle	Single needle	Two needle	Single needle	Two needle
Max. sewing speed	3,500 s.p.m.			
Max.stitch length	15/32" (12 mm)			
Clearance under presser foot	by hand	23/64" (9 mm)		
	by automatic foot lifter	25/32" (20 mm)		
Needle bar stroke	1-37/64" (40 mm)			
Needle	DP x 17 (#16 - #23) , 135 x 17 (#120 - #160)			
Thread	#20 - #5			
Hook	Extra Large vertical axis hook (2.7 times)			
Amount of lift of walking foot	3/64" - 23/64" (1.0 - 9.0 mm)			
Thread take up lever	Link type			
Lubrication	Automatic lubrication type			
Bed size	23-13/16" x 8-3/16" (605 x 208 mm)			
Working space	13-25/32" x 5-1/8" (350 x 130 mm)			
Motor	Built-in 850W Direct drive motor		850W AC Servo motor (exclusive for BLW)	
Net weight(Head only)	70Kg		66Kg	

NOTE: (1) Speed depends on threads, materials and type of operation.
 (2) Specifications subject to change without notice.



SEIKO SEWING MACHINE CO., LTD.

2-13-6, Sakaecho, Funabashi-shi
 Chiba Prefecture, 273-0018, Japan
 Phone : +81-47-420-3561 (Overseas dept.)
 Fax : +81-47-420-3560
 E-mail : exsales@seiko-sewing.co.jp



Printed in Japan 2021.11

<http://www.seiko-sewing.co.jp/>